

Technical Specifications

55564

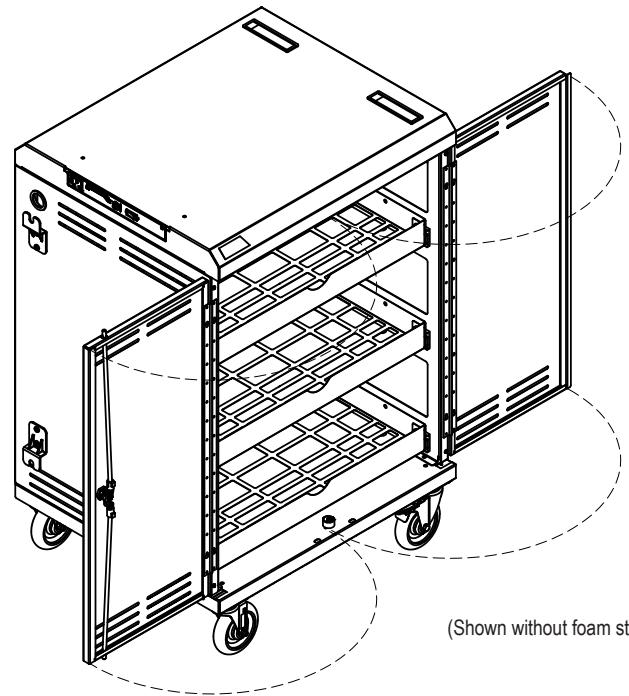
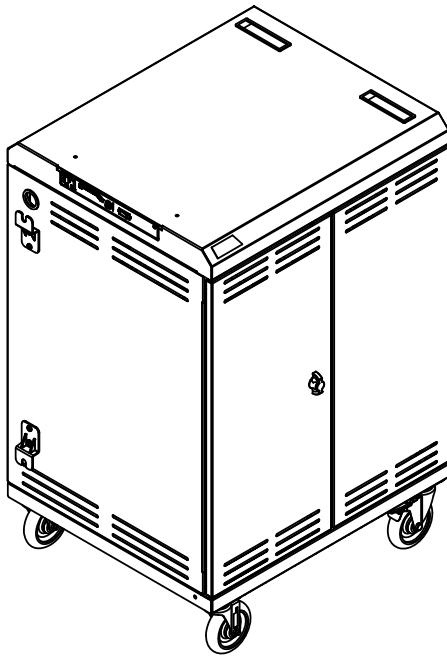

(Shown without foam storage)

Store, charge, protect, and transport your valuable VR equipment with the Immersion XR Cart. Available with custom-fit foams for Quest 2 Elite or Soft Strap, Edupro or Pico Neo 3 goggles and optional universal foam options for USB-A or USB-C charging, it stores up to 30 goggles and controllers in one location.



Features and Benefits

- Stores, charges, and transports up to 30 VR goggles and controllers*
- Drawer storage supports quick deployment with easy wiring and goggle storage
- Safety mechanism allows only one drawer to be pulled out at a time to prevent tipping
- Polyethylene foam padding protects devices
- Universal drawer version provides: 25"W [63.5 cm] x 22"D [55.9 cm] x 10"H [25.4 cm]
- Internal and external auxiliary AC outlets available to power other equipment/devices
- Cord management system keeps charge cords organized at each drawer
- Small cart footprint (29"W x 25"D) saves valuable space
- Cord wraps secure power cord while mobile
- Heavy gauge dual front doors with a dual-bolt keyed lock provides security for devices
- Rear panel is removable (via internal fasteners) to provide access if needed
- Power switch provides continuous power to all three 10-outlet power units (non current-sensing). **For most power adapters up to 45W**
- Includes (3) 10-port USB Type A chargers
- External power switch provides easy-access for safe power connection / disconnection
- Replaceable, IEC (quick-release) 8' nominal 14 AWG, 3-wire power cord and external recessed cord wrap brackets provide easy power access
- Ventilated doors and side panels keep devices and chargers cool, preventing overheating, and extending device life
- Four inboard 5" balloon wheel plate casters (two locking, two non-locking) with metal construction and non-marring rubber provide easy rolling, and quiet transport (rated for 300 lb each)
- Integrated handles in top panel provides control and maneuverability
- Cart ships fully-assembled for quick, simple integration and deployment
- Durable powder coated steel chassis provides a long-lasting finish
- Electrical system ETL certified to UL 60950-1 in the US and Canada
- Warranted to be free of all defects in materials and workmanship for 10 years, electrical system 2 years
- Designed and assembled in Chippewa Falls, WI, USA

Available models:

55564-WGUWF1	for Quest 2 Elite goggles and controllers (holds up to 24 sets)
55564-WGUWF2	for Quest 2 Soft Strap goggles and controllers (holds up to 30 sets)
55564-WGUWF3	for Edupro goggles and controllers (holds up to 30 sets)
55564-WGUWF4	with universal (flat) foam and USB-A charging
55564-WGUWF5	for Pico Neo 3 goggles and controllers (holds up to 15 sets)
55564-WGUWF6	with universal (flat) foam, and USB-A charging with USB-C adapters

Colors

Warm Gray (cabinet)	White (door)
---------------------	--------------

*Goggles and controllers not included

Construction

- 16-gauge top cover
- 20-gauge doors, side panels, rear panel, and base
- All metal components are finished with a scratch-resistant powder coat epoxy
- Medium density, closed cell, crosslinked polyethylene protective foam in drawers (grey color)
- This cart is factory-assembled, packaged, and shipped on its own skid. The foam kits and chargers will be in a separate box.

Specifications

Capacity	<ul style="list-style-type: none"> • Up to (24) Quest 2 Elite goggles and controllers • Up to (30) Quest 2 Soft Strap goggles and controllers • Up to (30) Edupro goggles and controllers • Up to (15) Pico Neo 3 goggles and controllers • (Varies) Universal flat foam
Drawer capacity (nominal) <i>(See p.4 for foam storage)</i>	<ul style="list-style-type: none"> • Drawer storage: 25"W [63.5 cm] x 22"D [55.9 cm] x 10"H [25.4 cm] • Max weight per drawer: 25 lb [11.35 kg]
5" Balloon Wheels	Weight capacity 300 lb [136.2 kg] each (2 locking, 2 non-locking)
Certifications / Compliance	Meets or exceeds applicable ANSI-BIFMA test standards
Unit weight (nominal)	143 lb [65 kg]
Shipping weight (nominal)	170 lb [77.2 kg]

Specifications subject to change without notice

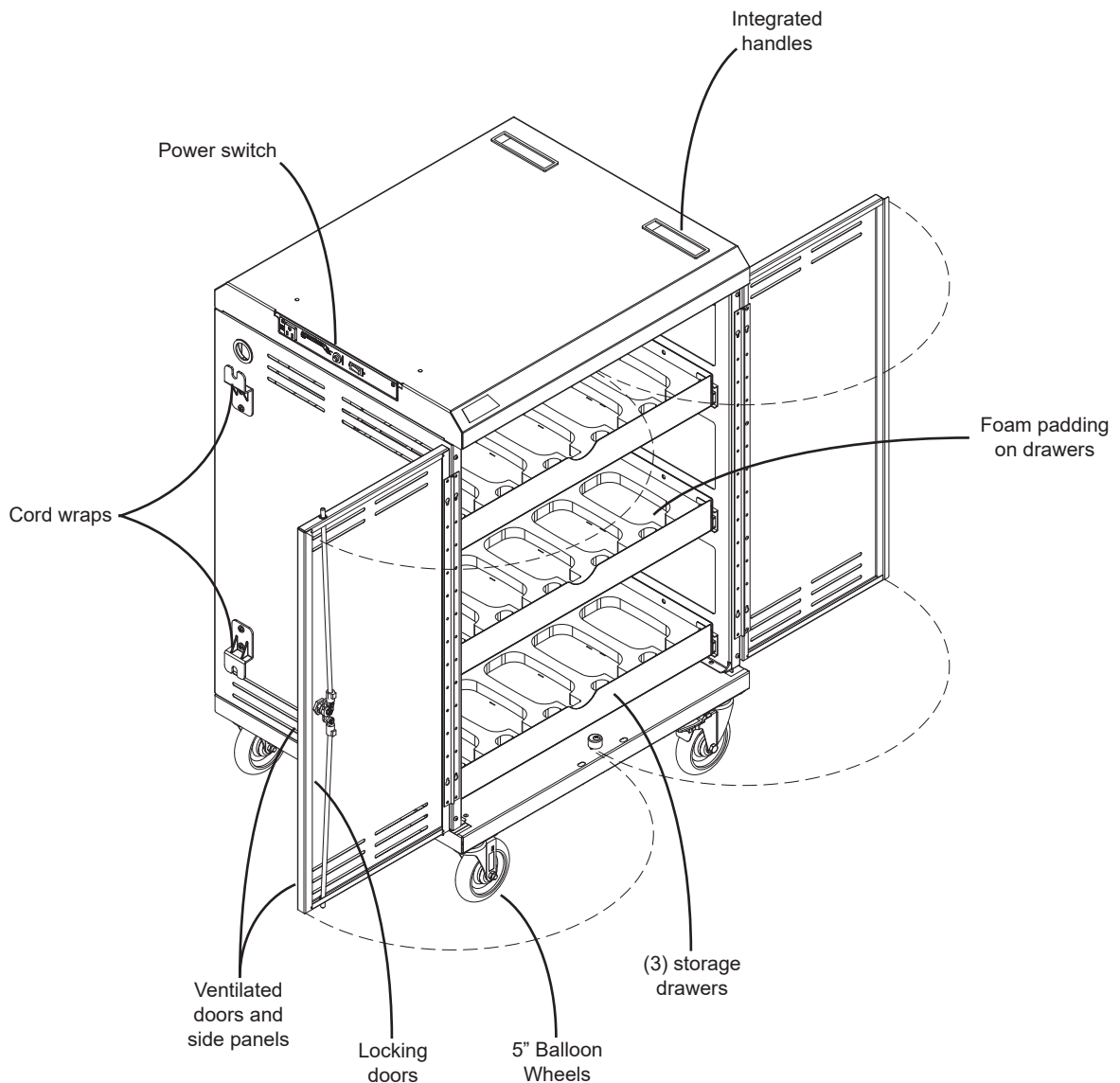

Electrical

Power Switch

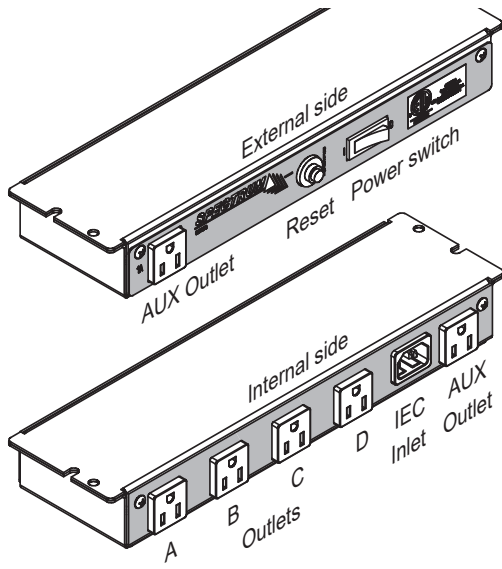

- Provides continuous power to four continuous dedicated outlets (labeled A, B, C, D)
- Two auxiliary outlets (1 external, 1 internal)
- ETL certified to 60950-1

Input:	125V~/12A, 60Hz
Breaker:	15A, 250 VAC
Outlets:	4 timed (A, B, C, D) up to 10A
Auxiliary outlets:	1A each (controlled by main power switch)
Power Cord:	IEC quick-release (replaceable) 8' nominal, 14 AWG, 3-wire
Power switch:	15A (externally accessible)

USB Charger (3 included)



- 10 USB-A ports each (1 per drawer)
- Overcharging, overvoltage, and over-current protection, Smart IC Technology
- Compliance: FCC, RoHS

Dimensions:	2.8"W x 4.4"D x 1.1"H
Voltage required:	AC 100-240 V (50/60 Hz)
Voltage provided:	5V
Current provided:	2.4A per port
Output connectors:	Total 10: 10 x 4 pin USB Type A
Power Provided:	60W
Max electric current:	2.4A

Drawer cord management

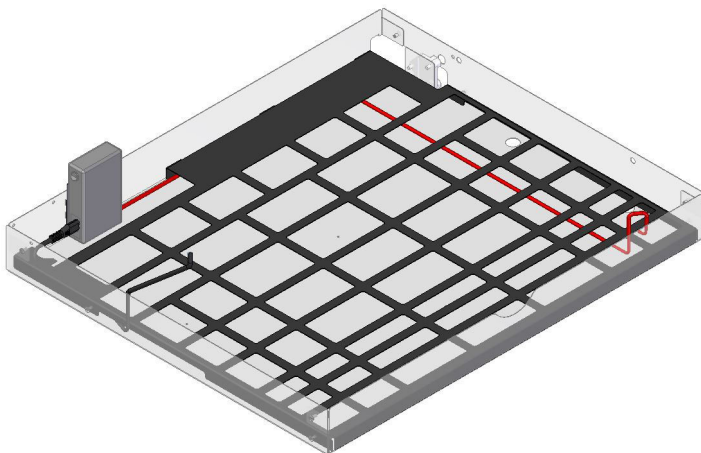

Each drawer has a raised grid that creates space to easily route charge cords and wires under the foam storage to the gogglers.

5" Balloon Wheel

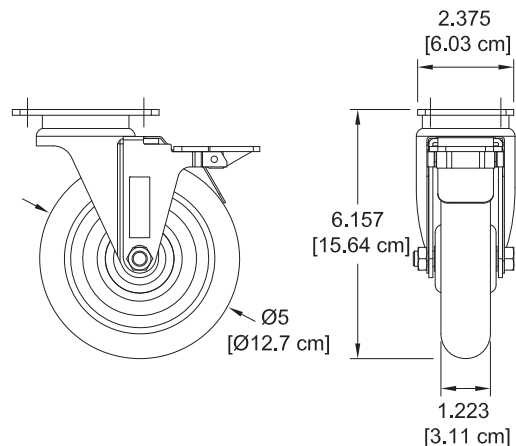

(2) locking, and (2) non-locking casters are included on each unit.

Drawer foam storage options

55564-WGUWF1

Custom-fit Quest 2 Elite Foam
with USB-C Charging Ports
(shown with Goggles and Controllers*)

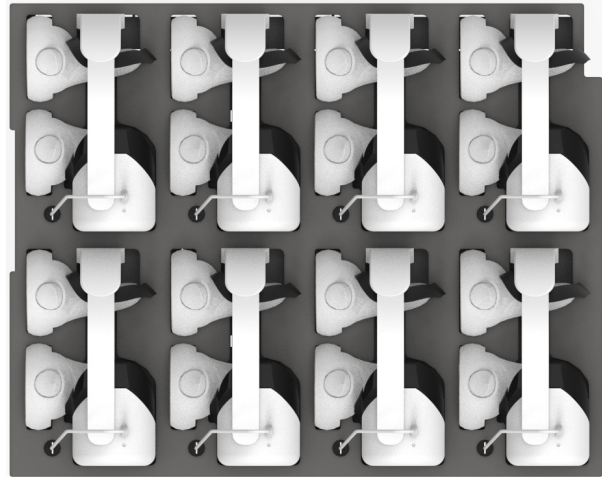
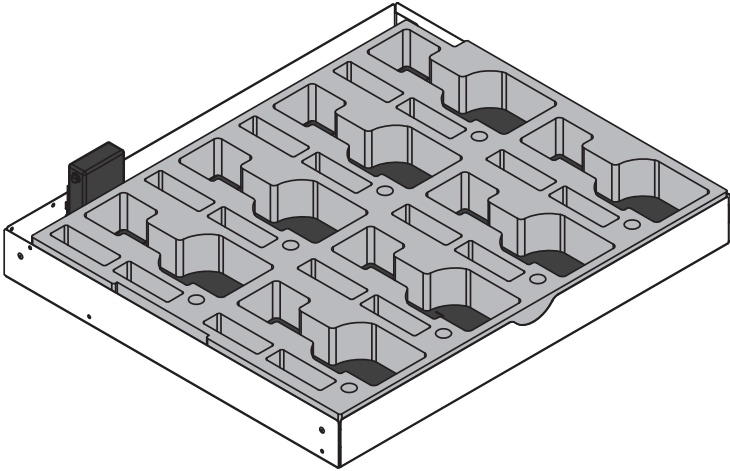

55564-WGUWF2

Custom-fit Quest 2 Soft Strap Foam
with USB-C Charging Ports
(shown with Goggles and Controllers*)

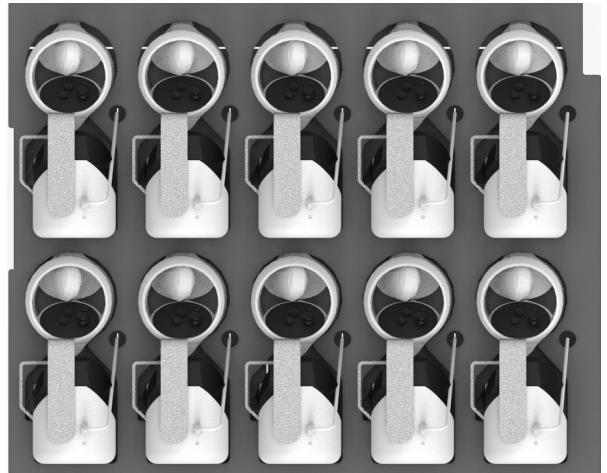
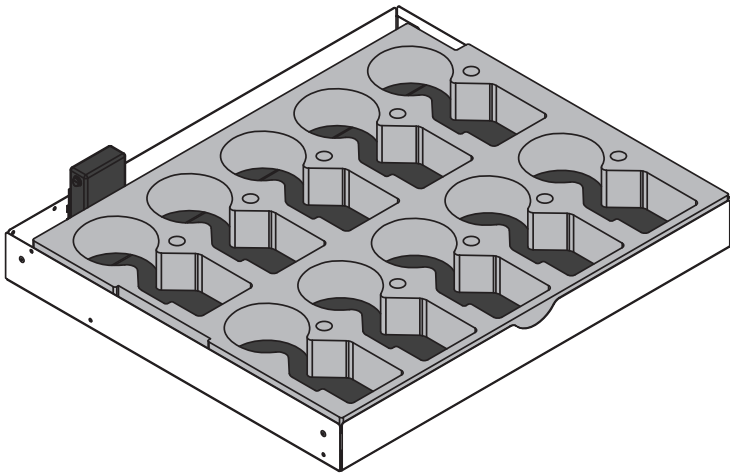

55564-WGUWF3

Custom-fit Edupro Foam
with USB-A Charging Ports
(shown with Goggles and Controllers*)

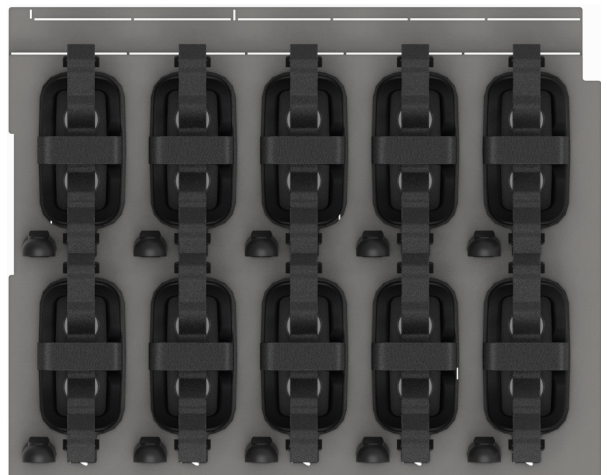
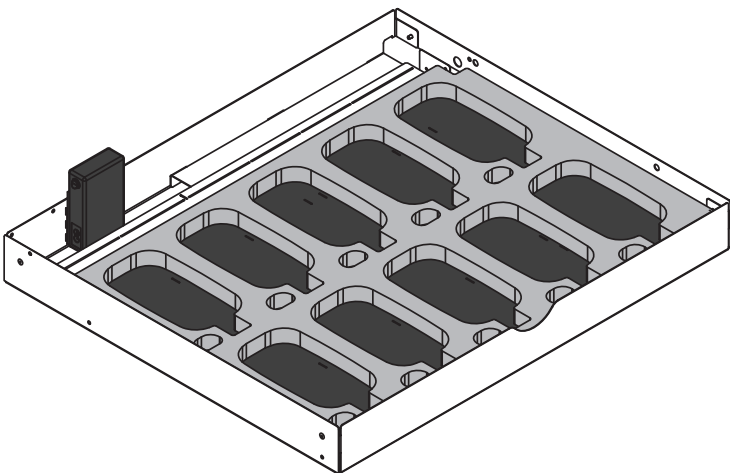

55564-WGUWF5

Custom-fit Pico Neo 3 Foam
with USB-A Charging Ports
(shown with Goggles and Controllers*)

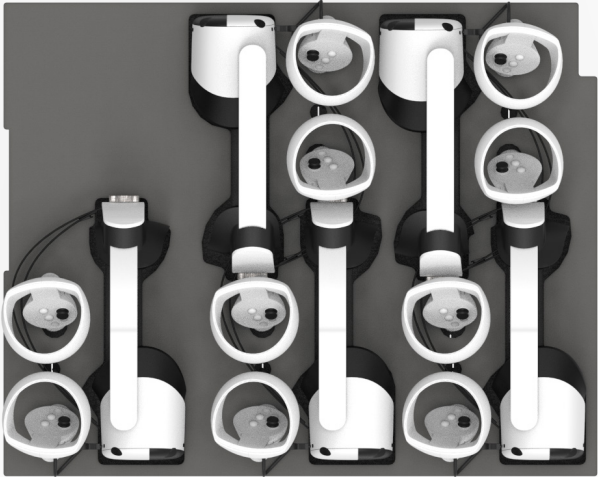
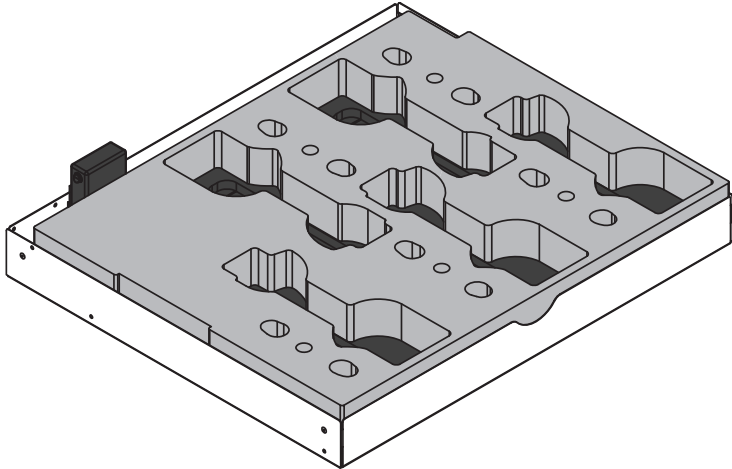

55564-WGUWF4 (USB-A)

or

55564-WGUWF6 (USB-A w/ USB-C adapters)

Universal Flat Foam

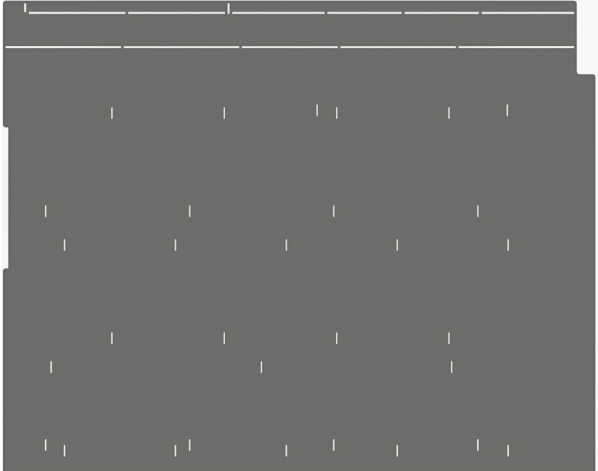
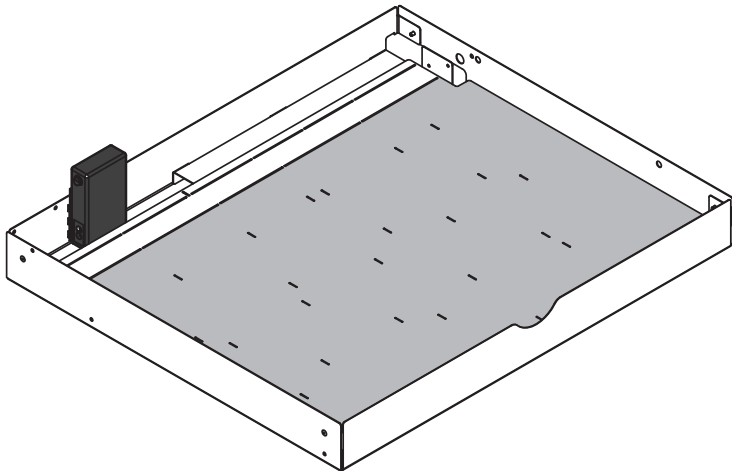

Storage available: 25"W [63.5 cm] x 22"D [55.9 cm] x 10"H [25.4 cm]

Note: The cart is designed with a safety mechanism that allows only one drawer to be pulled out at a time.
Max weight per drawer: 25 lb [11.35 kg]

Immersion XR Cart

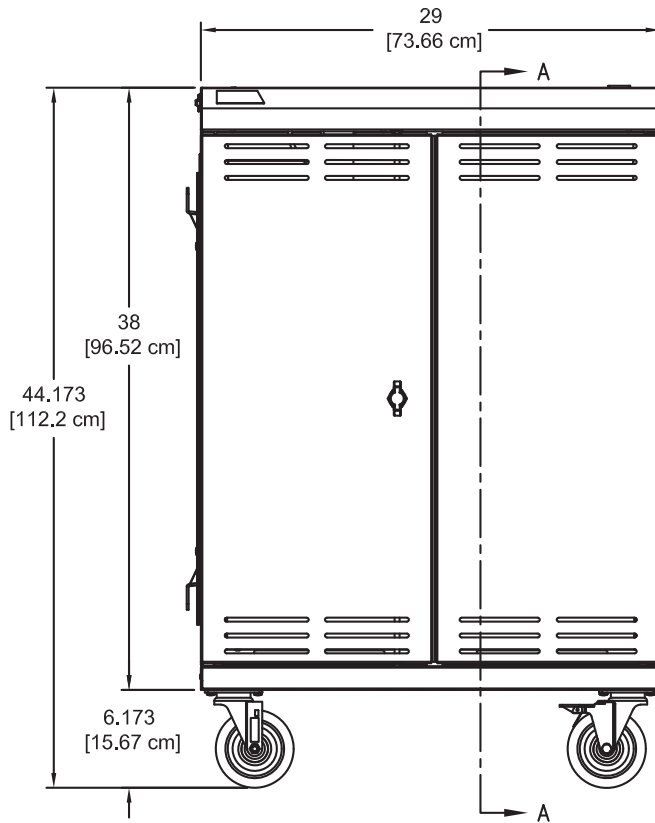
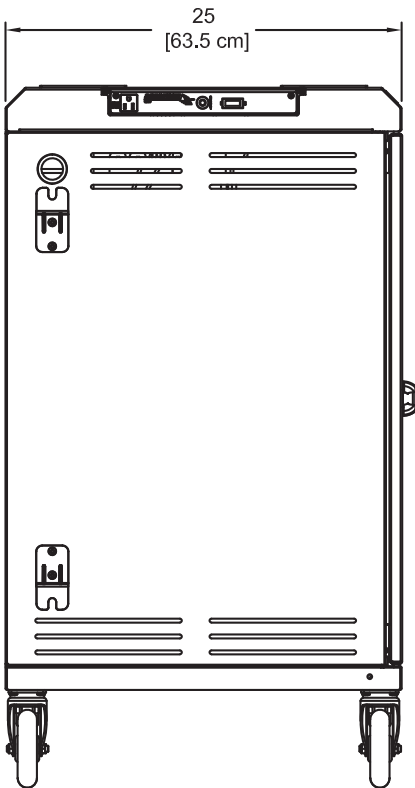
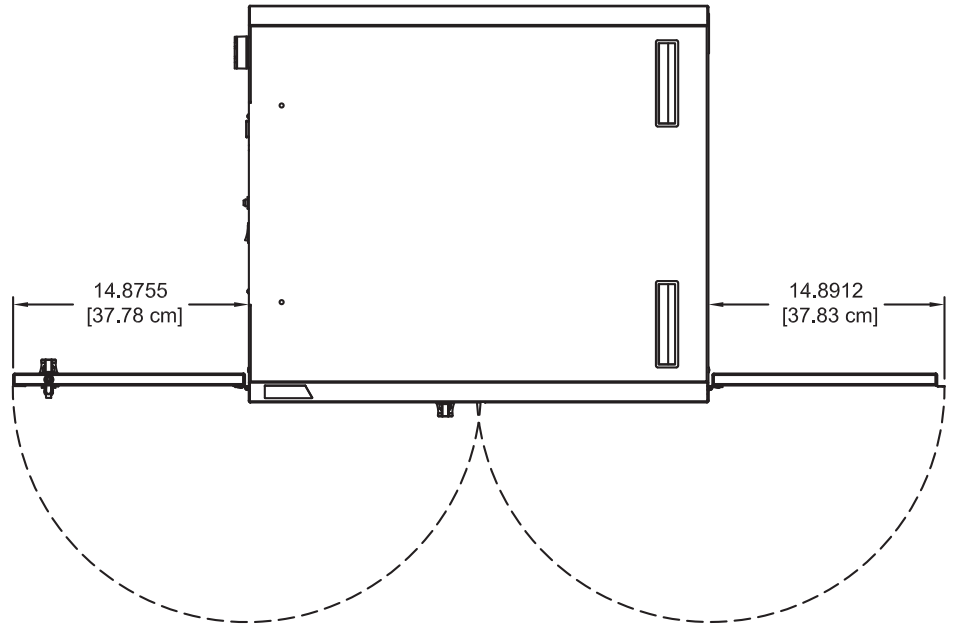
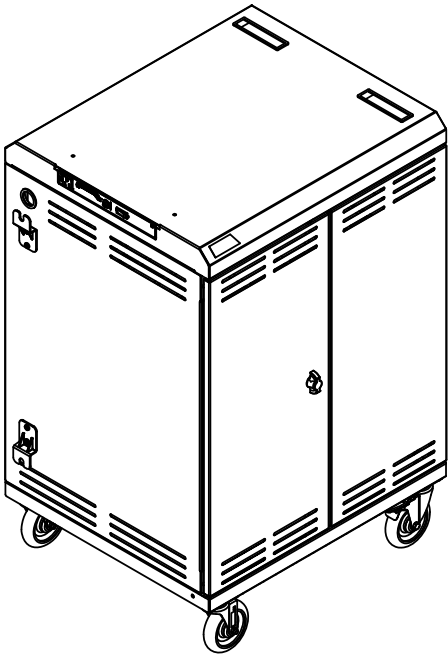

Immersion XR Cart
Section view A-A

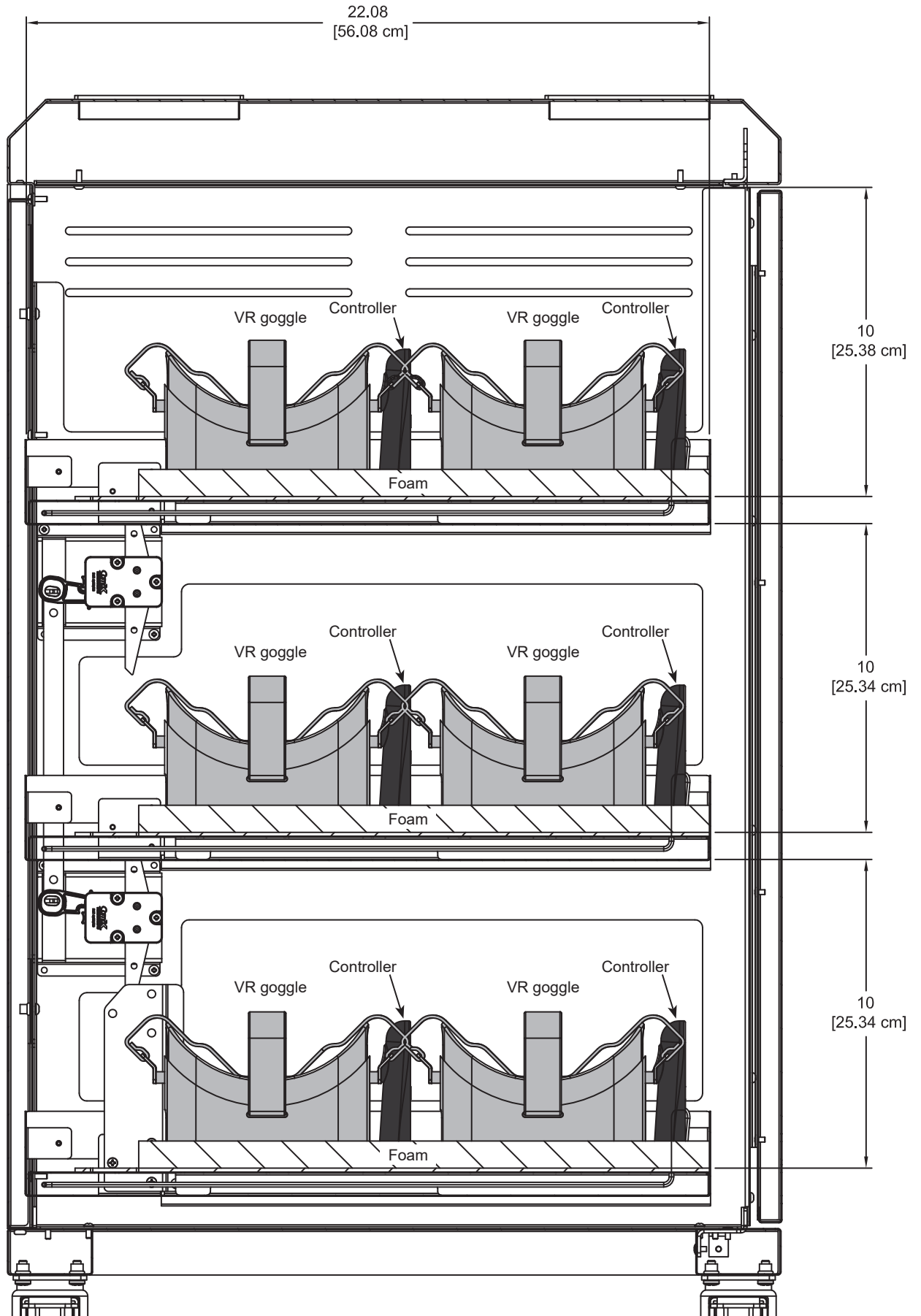

Immersion XR Cart
Wiring diagram

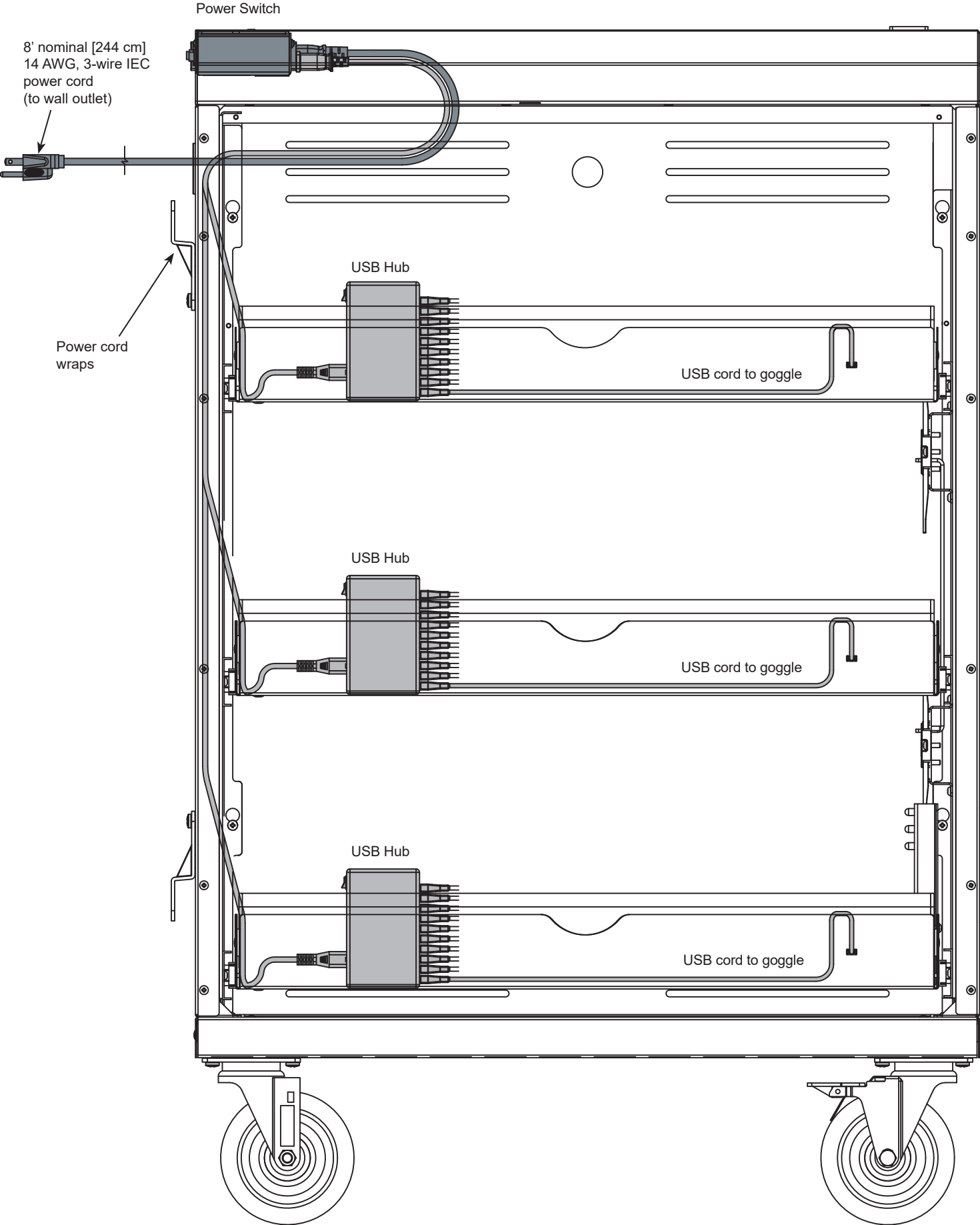

Accessories

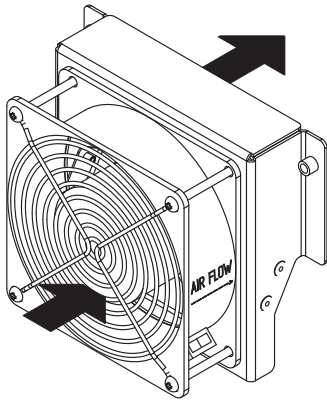

Cooling fan - 99062

- Exhausts hot air from inside cart
- Installs inside at top of cart
- Mounts to rear or side panel vent slots with two screws
- Customer-installed

Electric Fan:	<ul style="list-style-type: none">• Voltage: 115VAC (single phase)• Power: 5.5W• Current: .08A• 1450 RPM• Dimensions: 119 mm x 119 mm• Ball Bearing	<ul style="list-style-type: none">• Noise: 28 dB• Air flow: 49.4 CFM (1.40m³/min)• Frame material: Aluminum• Blade material: Polycarbonate, Fiberglass reinforced
Power cord:	18ga, 48" nominal length, 6A 125V~ (2 prong plug)	
Mounting bracket	<ul style="list-style-type: none">• 16-gauge steel• Black powder coat• Mounting screws included	
Unit weight:	N/A	
Shipping weight:	2 lb [.9 kg]	

See [spectrumfurniture.com](https://www.spectrumfurniture.com) for the latest accessories and detailed warranty information.

Warranty

We will make it right for you!

Thanks for choosing Spectrum! Spectrum is committed to provide complete customer satisfaction. Each of our products is manufactured from the best materials available and each product is stringently monitored throughout the production process through our P.A.C.E. program (Product Assurance to meet Customer Expectations).

We expressly warrant that Spectrum products will be of good quality and workmanship and free from defect for the period set out in the warranty from the date of delivery.

For a listing of all product specific warranty terms please visit our website at:

<https://www.spectrumfurniture.com/en/resources/purchasing-terms-warranty>

1-800-235-1262

Toll-free HELPLINE

spectrum@spectrumfurniture.com